

**Submission Data: 36RLXFZ
Inverter Driven Heat Pump**

36,000 BTU Multi-Zone System

Job Name: _____

Date: _____

Location: _____

Approval: _____

Engineer: _____

Construction: _____

Submitted to: _____

Unit #: _____

Submitted by: _____

Drawing #: _____

Reference: _____

General Features

- Wired or wireless remote
- Apple catechin filter
- Ion deodorizing filter
- Auto louver: up/down
- Auto louver: 4-way
- Low ambient cooling
- Blue fin coating
- Standard Warranty: 5 years parts, 7 years compressor. Applies to systems purchased before June 1st 2015*
- Extended Warranty: 10 years parts, 10 years compressor. Systems that have been installed on or after June 1st 2015 by licensed contractors and the online Product Registration has been submitted.**
- Elite Contractor Extended Warranty: 12 years parts, 12 years compressor. Systems that have been installed on or after June 1st 2015 by contractors who have met requirements and have been approved for elite contractor status plus, the online Product Registration has been submitted.***

Model Information

Condenser.....	AOU36RLXFZ
Evaporator^.....	(ASU) / (ARU) / (AGU) / (AAU) 7,9,12,18RLF(1)
Connectable indoor units.....	2 - 4
Total capacity range.....	27,000 – 39,000 Btu/h
Electrical	208/230V AC 1ph-60Hz
Available Voltage Range.....	208/230 +/- 10%
Minimum Circuit Ampacity.....	20.1 A
Max Fuse Size.....	30 A

Current

Starting Current.....	15.1 A
Max Operating Current.....	20.1 A
Cooling.....	(non-duct) 17.5 A / (ducted) 18.1 A / (mix) 17.8 A
Heating.....	(non-duct) 13.1 A / (ducted) 15.1 A / (mix) 14.1 A

Input Power

Cooling.....	(non-duct) 4.00 kW / (ducted) 4.15 kW / (mix) 4.07 kW
Heating.....	(non-duct) 3.00 kW / (ducted) 3.45 kW / (mix) 3.21 kW

Capacity

Nominal Cooling.....	35,200 Btu/h
Min-Max Cooling.....	11,000 – 36,000 Btu/h
Nominal Heating.....	36,400 Btu/h
Min-Max Heating.....	11,000 – 42,000 Btu/h

Compressor

Motor Output.....	DC Twin Rotary (inv x1)
Refrigerant.....	1,300 W
Pre-Charge.....	R410a
Oil.....	7 lbs. 4 oz.
	POE

Fan Motor

Type: DC (condenser).....	Propeller x1
Motor Output (condenser).....	100 W
Type: DC (evaporator).....	(wall-mount) Cross flow
	(compact cassette) Turbo
	(ducted) Sirocco x2 (18 k x3)
	(floor) Cross flow x2

Motor Output (Evaporator).....	(wall) 30-42W (compact cassette) 54W (ducted) 80-81W
	(floor) 16W

Heat Exchanger

Dimensions (condenser)	(H x W x D) in. (mm)..... 31-13/32 x 35-7/16 x 1-7/16 (798x900x36.38)
Fin Pitch.....	20 FPI
Rows x Stages.....	2 x 38
Pipe Type (Material).....	Grooved H-Pin (Copper)
Fin Type (Material).....	Aluminum (Blue fin)

Operation Temperature Range

Cooling.....	32°F - 115°F (-10°C - 46°C)
Heating.....	14°F - 75°F (-15°C - 24°C)

Efficiency

SEER ^{AA}	(wall-mount) 16.0 (duct) 14.50 (mix) 15.25
EER (cooling).....	(wall-mount) 8.80 Btu/W (duct) 8.10 Btu/W (mix) 8.45 Btu/W
COP (heating).....	(wall-mount) 3.56 W/W (duct) 3.08 W/W (mix) 3.32 W/W
HSPF (heating).....	(wall-mount) 9.40 (duct) 8.70 (mix) 9.05

Enclosure (condenser)

Material.....	Painted galvanized steel
Color.....	Beige (10 YR 7.5/1.0 NN)

Sound Pressure Level

Cooling.....	53 dB(A)
Heating.....	55 dB(A)

Dimensions

H x W x D (condenser)	32-11/16 x 35-7/16 x 13 (830x900x330)
Net in. (mm).....	38-3/16 x 41-5/16 x 17-1/2 (970x1,050x445)

Connection Pipe

Liquid.....	1/4" (6.35 mm) x4
Gas.....	3/8" (9.52 mm) x3 + 1/2" (12.70 mm) x1
Method (Liquid/Gas).....	Brazing
Pre-charge length (Total).....	164 ft. (50m)
Max length (Total).....	230 ft. (70m)
Max length (Each).....	82 ft. (25m)
Min. length (Total).....	66 ft. (20m)
Min length (Each).....	16ft. (5m)
Max Height Difference.....	49 ft. (15m)

Weight

Condenser.....	149 lbs. (68kg)
Evaporators.....	(wall-mount) 19 lbs. - 31 lbs.
	(compact cassette) 33 lbs.
	(ducted) 37 lbs. - 49 lbs.
	(floor) 31 lbs.

Accessories

Wired Remote Controller.....	UTY-RVNUM
Wired Remote Controller.....	UTY-RNNUM
Simple Remote Controller.....	UTY-RSNUM

Intertek®ETL Number

AOU36RLXFZ.....	91987
-----------------	-------

Reference brochure for approved combinations. **Test conditions are based on AHRI 210/240. Note: Specifications are based on the following conditions: Cooling: Indoor temperature of 80°F (26.7°C) DB/67°F (19.44°C) WB, and outdoor temperature of 95°F (35°C) DB/75°F (23.9°C) WB. Heating: Indoor temperature of 70°F (21.11°C) DB/59°F (15°C) WB, and outdoor temperature of 47°F (8.33°C) DB/43°F (6.11°C) WB. Pipe length: 24ft. (7.5m). Height difference: 0ft. (0m) (Outdoor unit - indoor unit)

†Standard warranty. **10-year warranty. ***12-year warranty.

Fujitsu General America, Inc.
 353 Route 46 West
 Fairfield, NJ 07004
 Toll Free: 1-888-888-3424
 Fax: (973) 836-0447
www.fujitsugeneral.com



Dimensions:36RLXFZ

[Unit: in. (mm)]

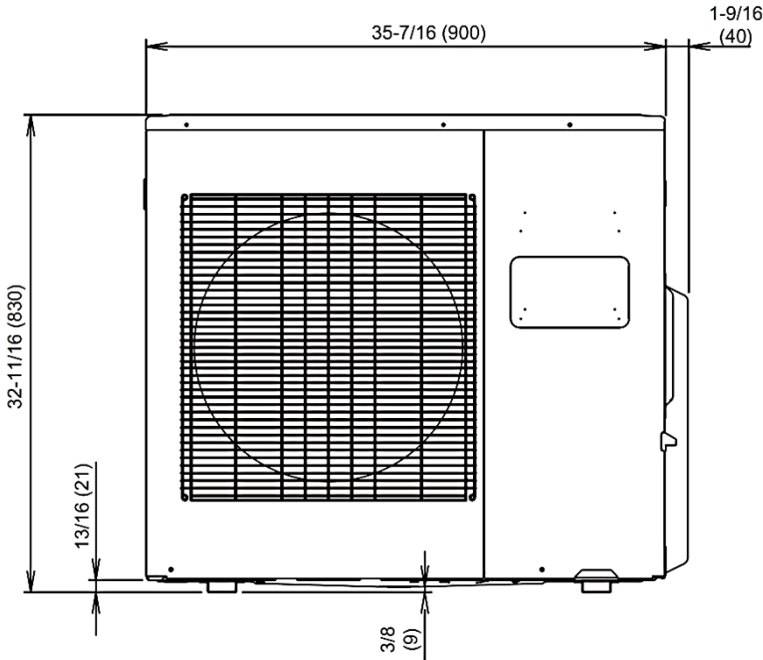

Front view

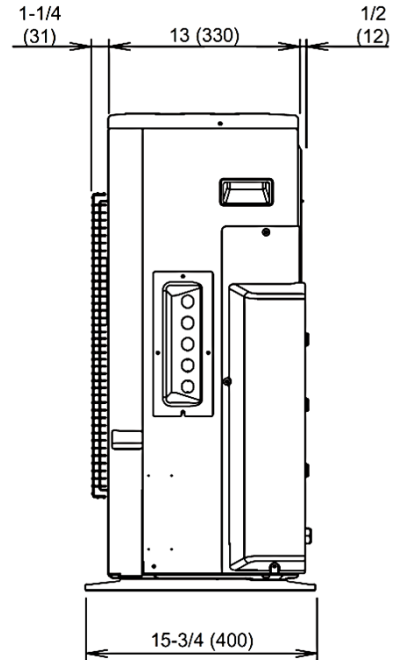

Side view

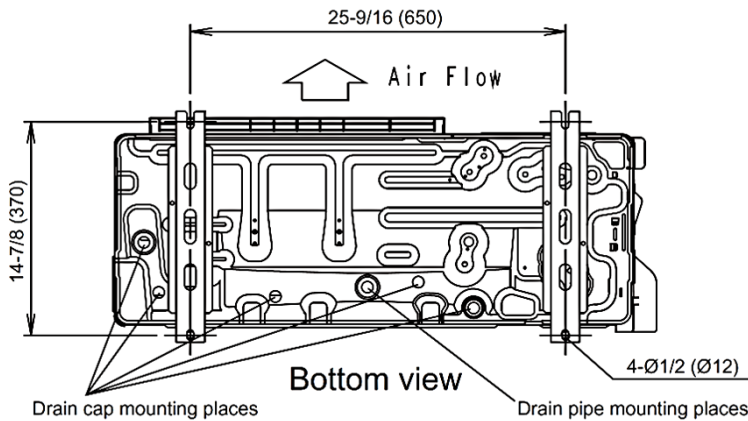

Bottom view

